

THE SHUROUQ COLLECTION



FROMM.

THE SHUROUQ COLLECTION

A collection inspired by Qatar's architecture, nature, and heritage, stands as a masterpiece of artistry.

Immerse yourself in the majestic hues of the desert dawn with this collection featuring rich gold tones and subtle nuances. This contemporary take on a traditional majlis draws inspiration from the local pigeon towers and desert dunes, incorporating unique design elements.

Designed in Doha, manufactured with meticulous attention in Italy, every detail in this collection is designed to mesmerize; its graceful curves and waves instill a sense of peace as if one is enveloped in the golden hues and rhythmic movements of sand dunes.

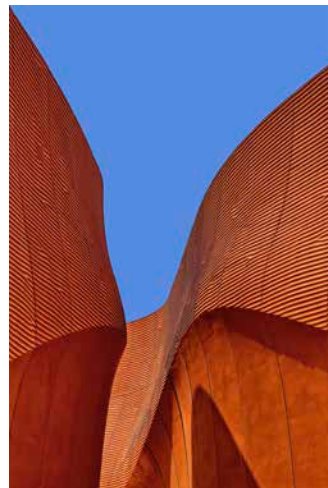

FROMM.

FROMM. is a luxury contemporary furniture and accessories brand founded in Msheireb and Milan, creating the ideal fusion of design and manufacturing. We collaborate with local and international designers to create collections that blend heritage innovation and contemporary aesthetics.

FROMM. Lab, is an educational and talent scouting platform, providing designers with an opportunity to collaborate and contribute to FROMM.'s collections and projects through workshops, mentorship programs, and our co-design process. These collaborations are represented locally, globally and showcased at the largest events in the industry.

DESIGNERS



DESIGNERS

MARYAM AL SUWAIDI

Maryam Al Suwaidi, a Qatari designer, joins the FROMM. Design Team with a strong background. She has completed a bachelor's in fine arts (interior design) and MA in Urban planning and Design, from Virginia Commonwealth University, School of Arts in Qatar. She is currently a Ph.D. candidate in Urban Design.

SHUA'A ALI

Shua'a Ali, a Qatari self-taught designer joins the FROMM. Design Team with a wealth of experience. In parallel with her background in Computer Science, she developed a passion and interest in art in the early stages of her life while living abroad in various cities, granting her exposure to diverse cultures and traditions.

KALTHAM AL KUWARI AISHA AL MOHANNADI

Kaltham Al Kuwari and Aisha Al Mohannadi, both Qatari designers, graduated from Virginia Commonwealth University with BFA in Interior Design with distinctive Magna cum laude honors. The duo credits their success to their evidence-based design approach, where they carefully study the needs of the client and project to ensure that they provide successful and aesthetically pleasing solutions.



HAIMA'

ARMCHAIR & POUF

Designer – Maryam Al Suwaidi

Haima' is an armchair worth a thousand words. Its characterful simple shell is based on a tender embrace. Each part of this piece effortlessly links to the other: from the backrest to the armrests, this piece of furniture was created with comfort as the leading principle.

ARMCHAIR
114 W X 102 D X 87 H cm

POUF
73 W X 62 D X 40 H cm

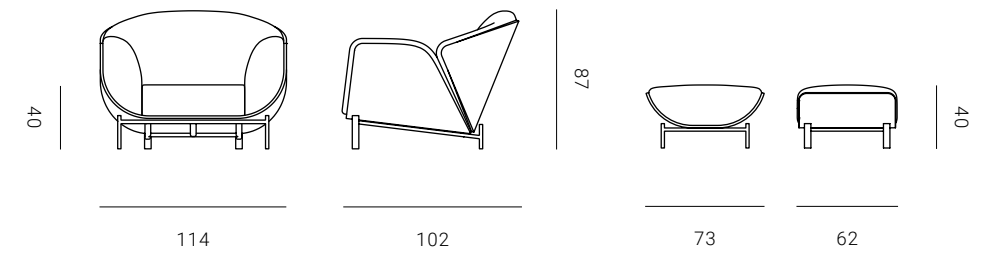





BAIDA'

SOFA

Designer – Maryam Al Suwaidi

Baida' sofa exudes confidence from every angle. Inspired by the desert dunes, this piece is characterised by appealing curves and twists. The Baida' sofa brings comfort from corner to corner, thanks to the knowledge of our master craftsmen.

SOFA 2 SEATER
170 W X 102 D X 87 H cm

SOFA 3 SEATER
240 W X 102 D X 87 H cm

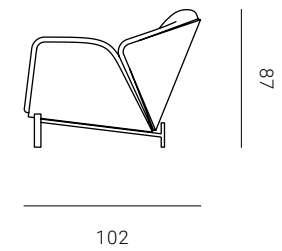
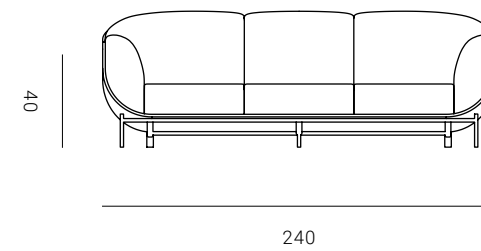
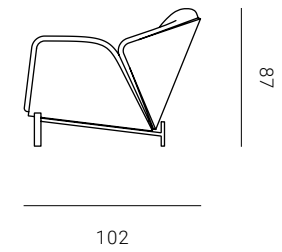
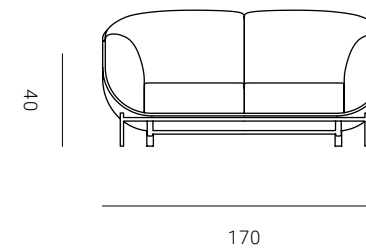

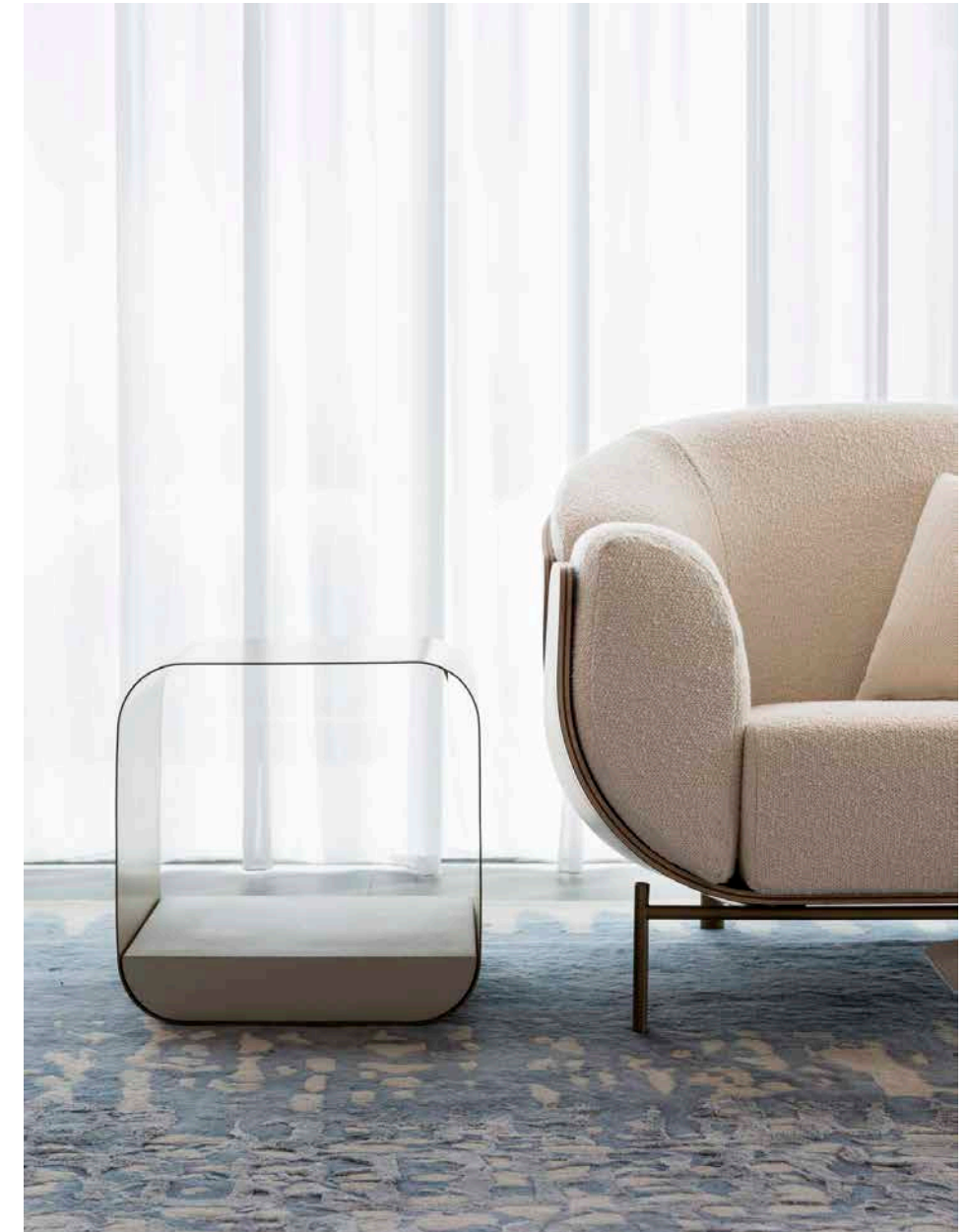



SOFRA

DINING TABLE

Designer – Kaltham Al Kuwari and Aisha Al Mohannadi

The Sofra Dining Table is a centerpiece that effortlessly merges the contemporary allure of blue ceramic with the opulence of gold. Crafted with meticulous attention to detail, this table features an organic shape surface that is reminiscent of the serene landscapes of Qatar. The interplay of the luxurious ceramic tabletop against the rich gold base creates a seamless fusion of modern design and natural elegance.

DINING TABLE
270 W X 125 D X 76 H cm

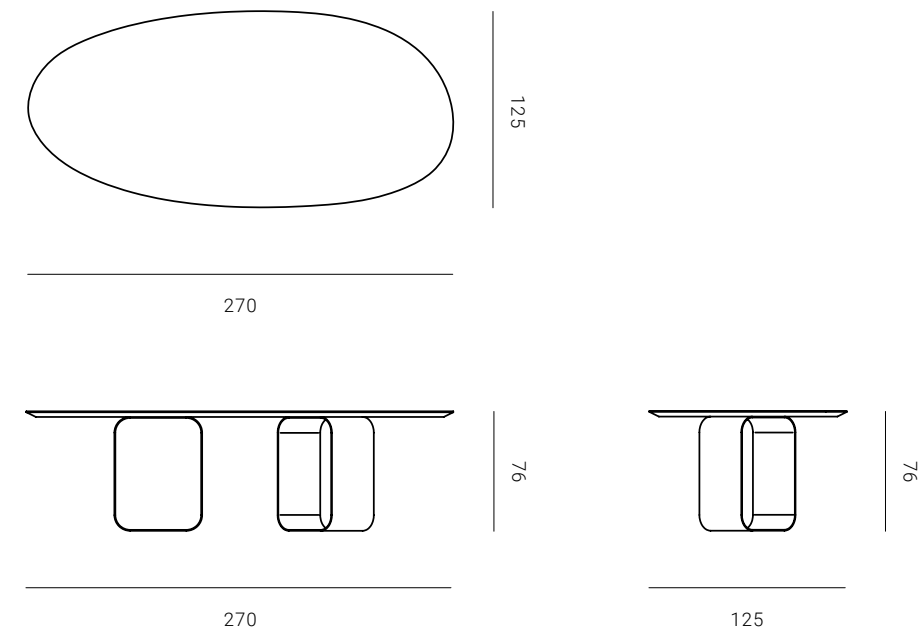



SANAD

DINING CHAIR AND ARMCHAIR

Designer – Kaltham Al Kuwari and Aisha Al Mohannadi

The Sanad dining Armchair and Chair are the embodiments of elegance and comfort. Their sculpted backrests, designed in an embracing form, offer a harmonious blend of comfort and style, echoing the serene beauty of Qatar's desert landscapes. The gracefully arched arms of the Armchair evoke the fluidity of sand dunes, while the Dining Chair's sleek silhouette complements its counterpart, bringing streamlined sophistication to any dining setting. Crafted from exquisite wood, both chairs pay homage to Qatar's rich heritage and natural allure.

SANAD DINING CHAIR
50 W X 60 D X 78 H cm

SANAD DINING ARMCHAIR
55 W X 60 D X 78 H cm

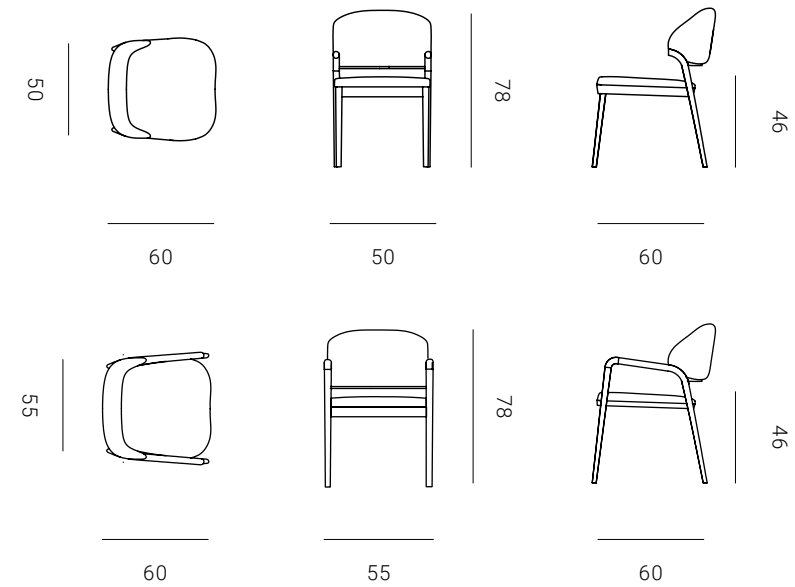



TAWLA

SIDE TABLE

Designer – Shua'a Ali

The Tawla piece is simplicity at its best. A smooth surface at just the right height designed to complement any living space. This table is intended to accessorize interiors discreetly or take center stage.

SIDE TABLE
50 W X 50 D X 51 H cm

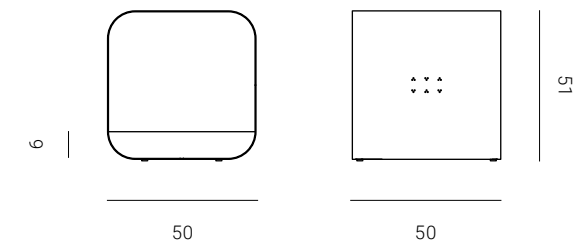

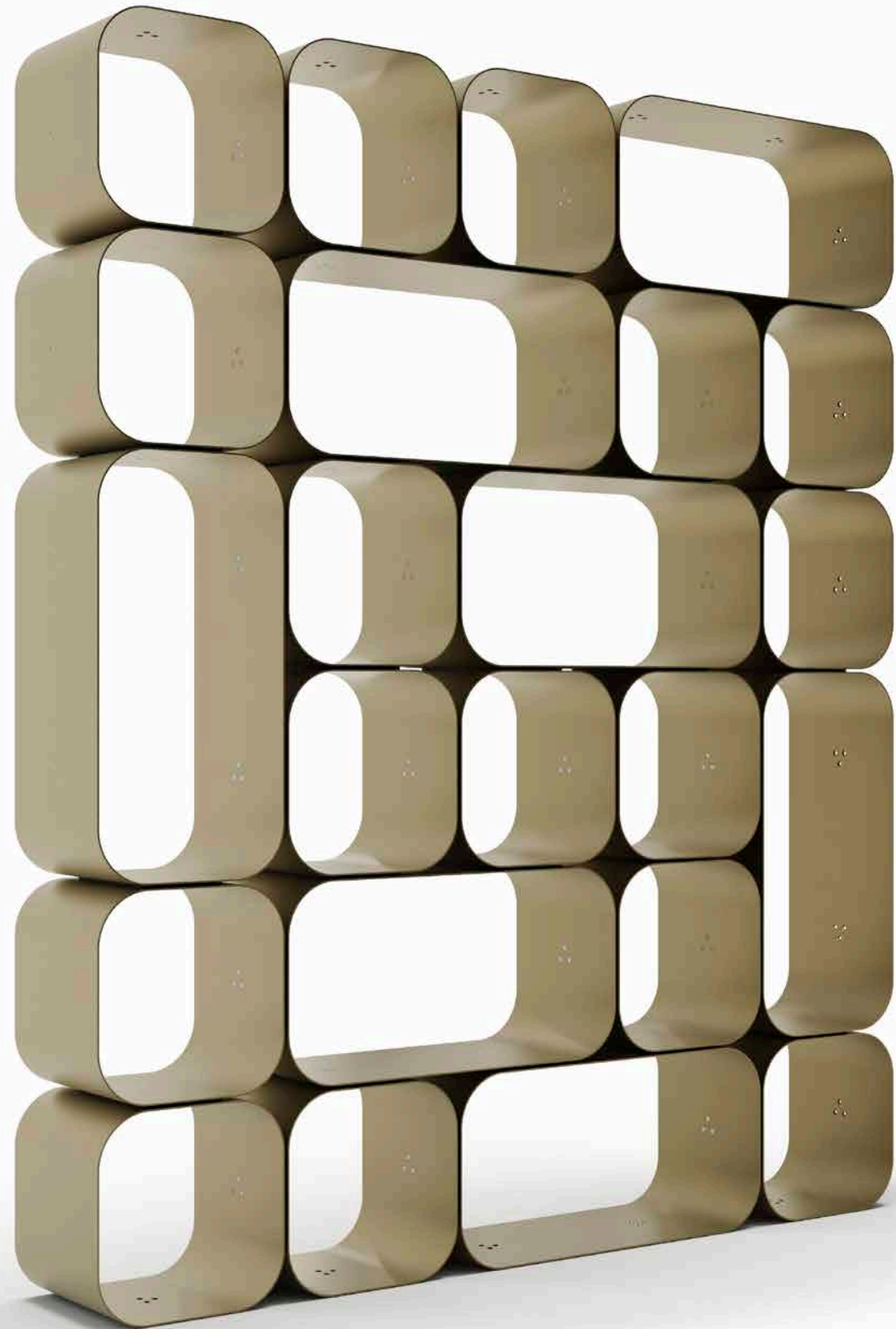

MAKTABA

WALL UNIT

Designer – Shua'a Ali

The Maktaba wall unit presents the perfect fusion between aesthetics and functionality. The balanced composition of shelving and cupboard units is the best storage solution for contemporary living spaces.

SMALL SIZE
142 W X 30 D X 177 H cm

LARGE SIZE
177 W X 30 D X 213 H cm

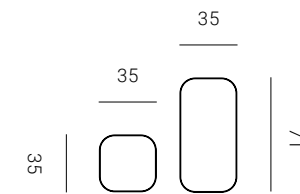

MODULARITY
Square and rectangular modules

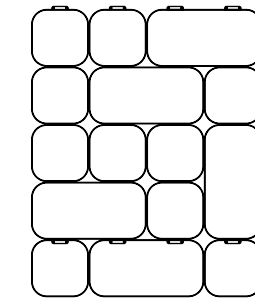

142

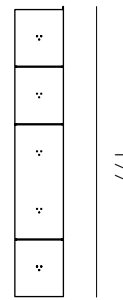

177

30

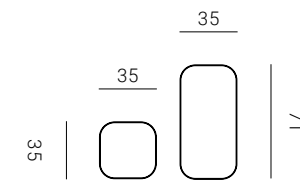

MODULARITY
Square and rectangular modules

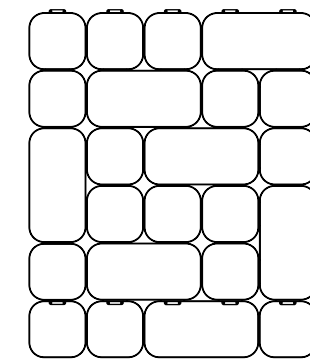

177

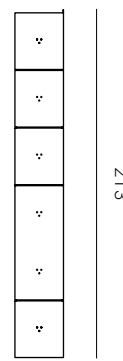

213

30

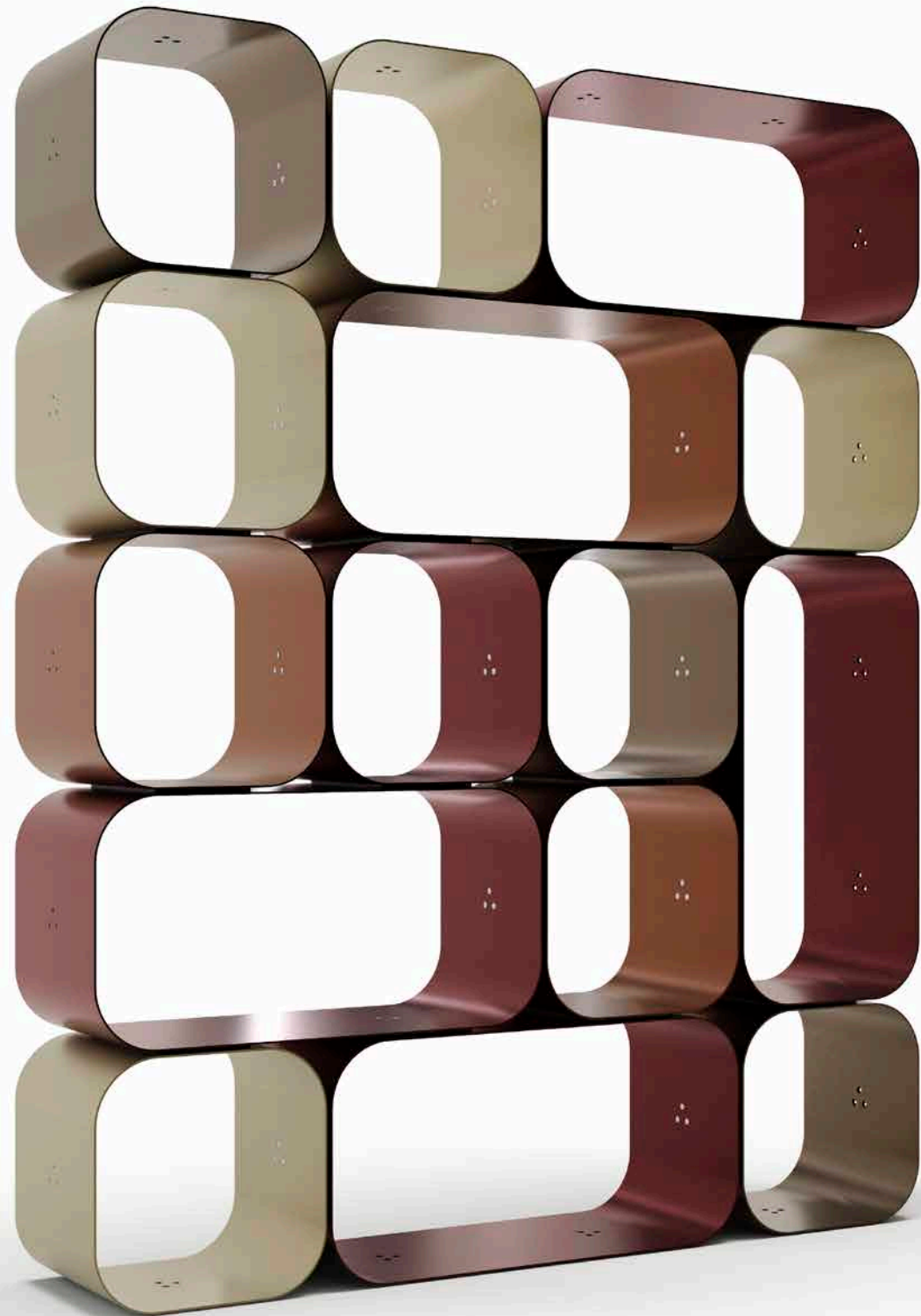

MAKTABA

MULTICOLOURED WALL UNIT

Designer – Shua'a Ali

The Maktaba wall unit, now presented in an elegant, earth-toned palette, draws inspiration from the desert's subtle beauty. With its minimalist design and clean lines, it offers a sophisticated solution for display and storage, enhancing contemporary spaces with refined simplicity.

MULTICOLOURED WALL UNIT
142 W X 30 D X 177 H cm

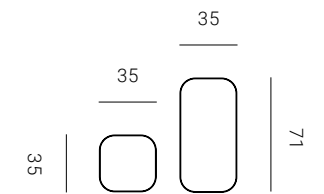

MODULARITY
Square and rectangular modules

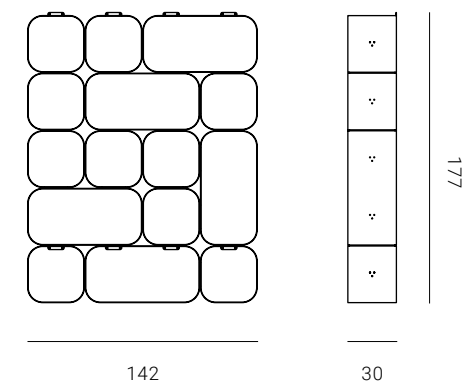



MAIZ

COFFEE TABLE

Designer – Shua'a Ali

Maiz blurs the lines between bold and simplistic to create a minimalistic expression of a coffee table that is both elegant and functional. The built-in concrete box serves as a space that can hold various objects and doubles as an incense burner, a cornerstone to Arab hospitality.

LARGE TABLE
140 W X 80 D X 35 H cm

SMALL TABLE
80 W X 80 D X 30 H cm

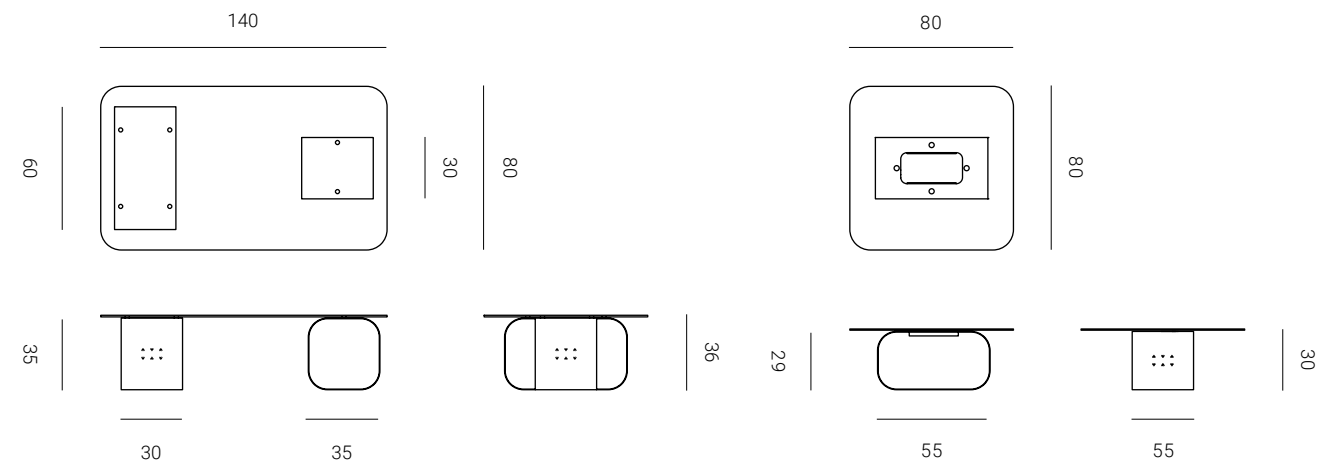



DERJ

CONSOLE DESK

Designer – Shua'a Ali

The Derj piece transforms any living space into your corner for professional ambitions and more. This piece serves as both a decoration and a functional workspace.

CONSOLE
130 W X 40 D X 86 H cm

DESK
128 W X 50 D X 75 H cm

BENCH
80 W X 42 D X 43 H cm

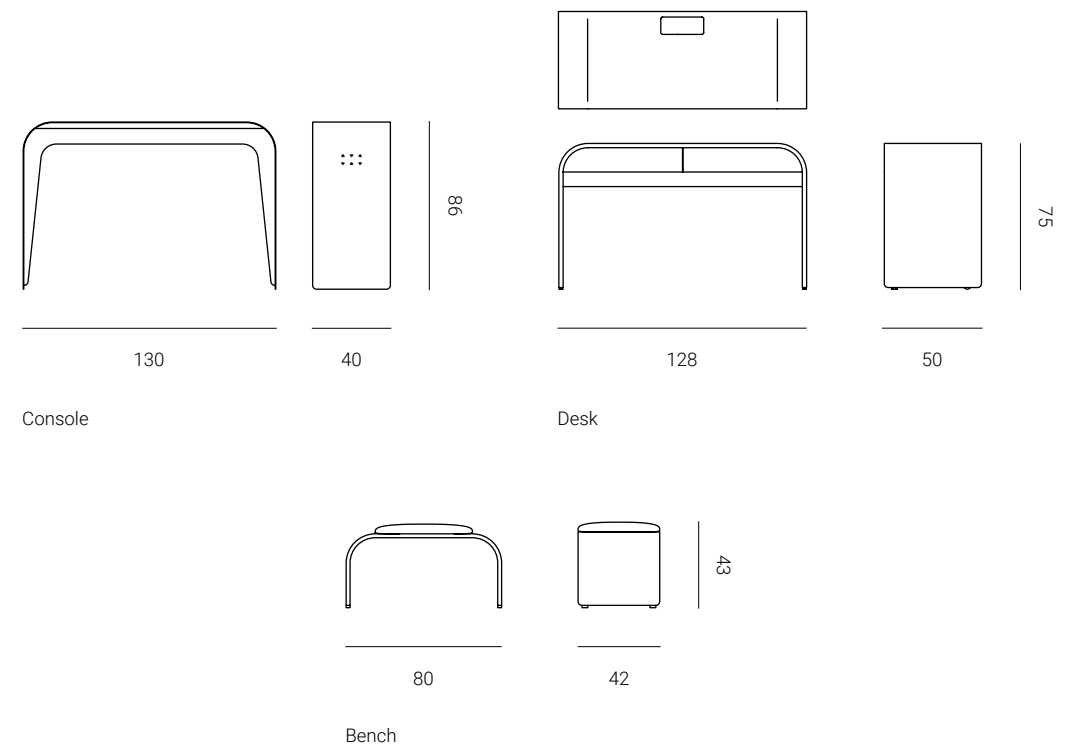





LAITE

FLOOR LAMP

Designer – Shua'a Ali X Studio Ellaquadro

Immaculately designed, this piece lights up any room and makes a statement doing so. A round top defines the aesthetics of the lamp, while providing a useful tray for small objects.

FLOOR LAMP
45 W X 45 D X 180 H cm

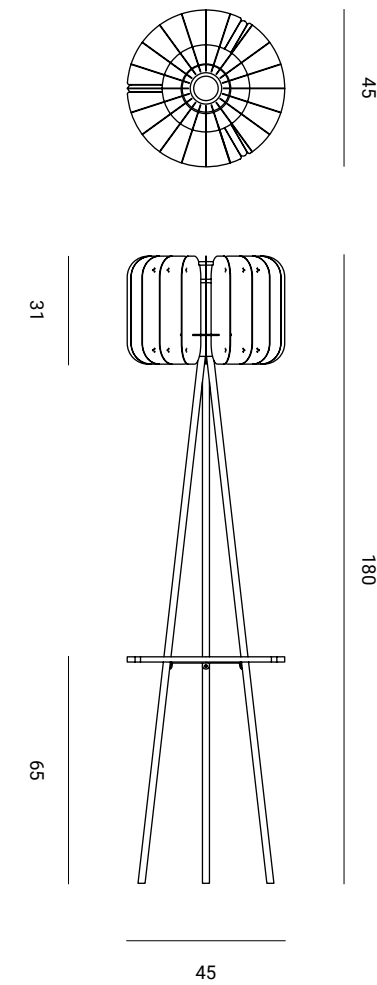



LAITE

CEILING LAMP

Designer – Shua'a Ali X Studio Ellaquadro

The Laite Ceiling Lamp adds a touch of sophistication to any living space, its modern design is perfectly complemented by its warm light.

CEILING LAMP
33 W X 110 H cm

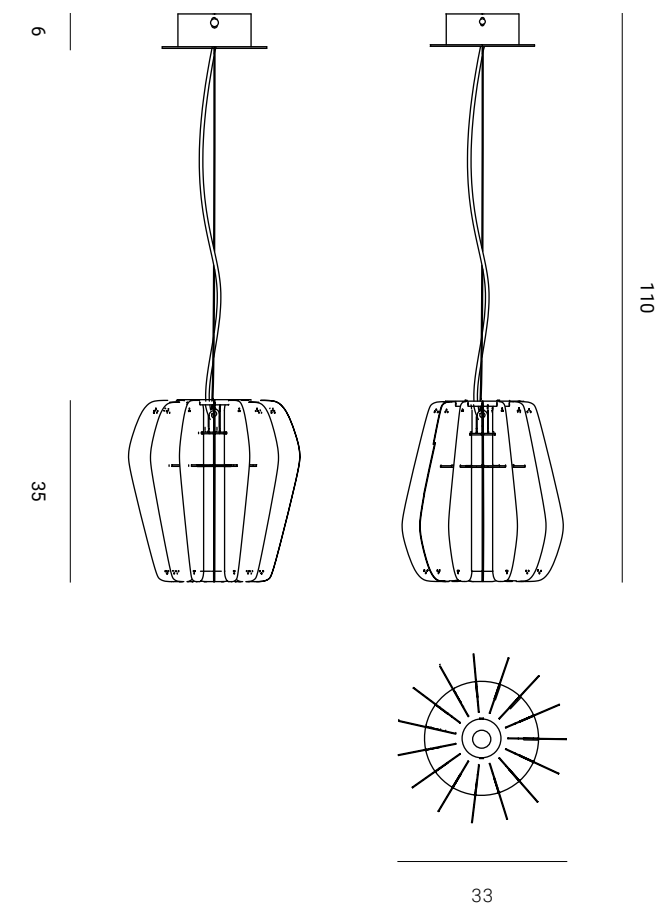

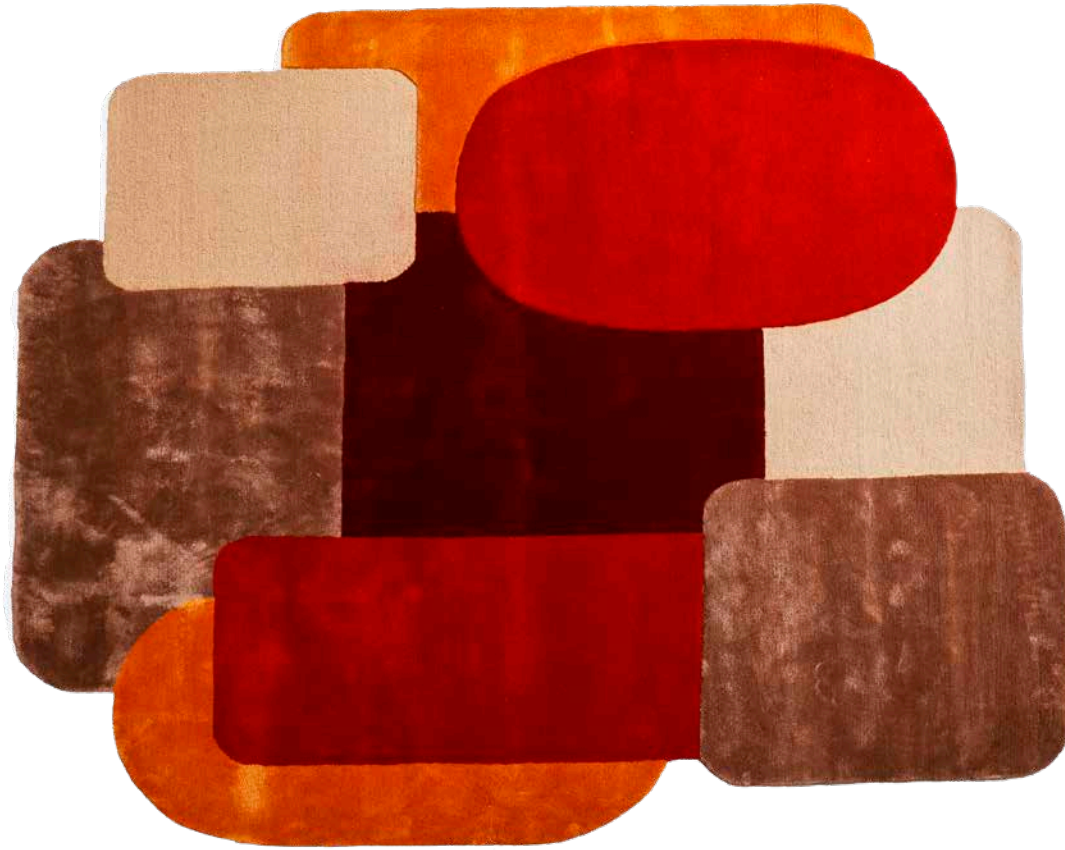

ZAL

CARPET

Designer – Shua'a Ali X KAHHAL 1871

Inspired by the traditional nomad-style tents of the Middle East, the Zal carpet innovates historic layering technique using color and texture. Its colors reflect the local desert and coastal landscapes of Qatar to create lasting beauty in any living space.

SMALL SIZE
250 x 220 cm

MEDIUM SIZE
300 X 260 cm

LARGE SIZE
360 X 315 cm

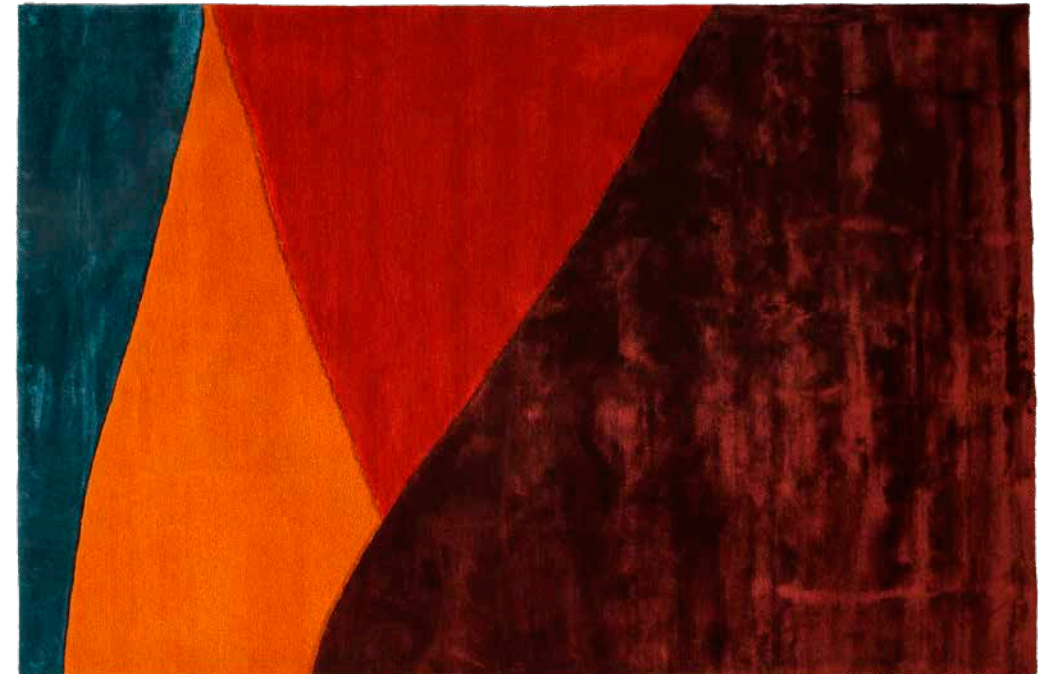

DUNES

CARPET

Designer – FROMM. X KAHHAL 1871

The Dunes carpet is intricately woven with varying heights and materials, including bamboo silk and New Zealand wool, to mirror the sand dunes of the Arab Gulf. It incorporates vibrant colors to enhance and elevate living spaces, adding a touch of contemporary elegance.

SIZE
360 X 315 cm



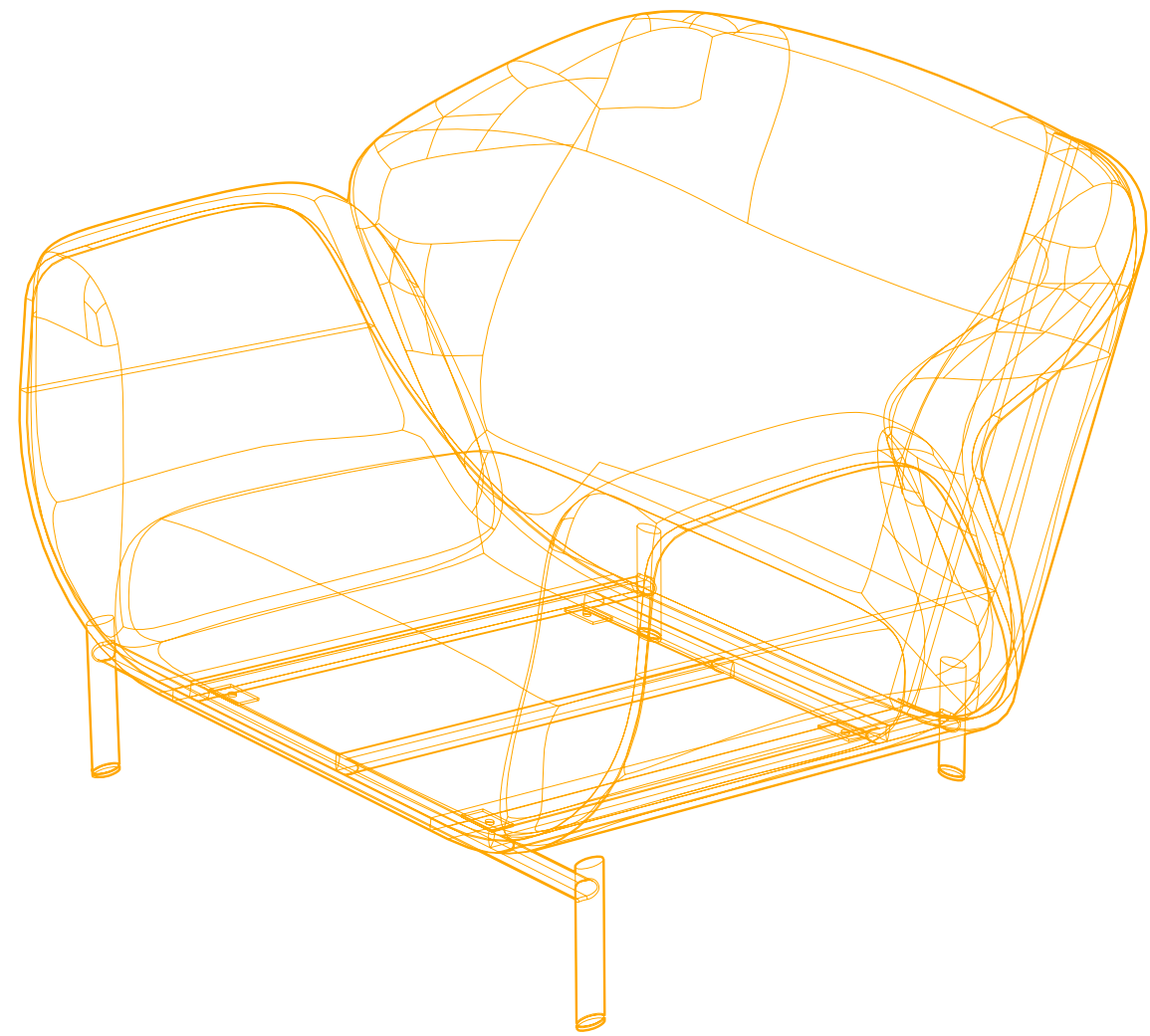

INDEX



HAIMA' ARMCHAIR
Designer Maryam Al Suwaidi
114 W X 102 D X 87 H cm

HAIMA' POUF
Designer Maryam Al Suwaidi
73 W X 62 D X 40 H cm



BAIDA' SOFA
Designer Maryam Al Suwaidi
Sofa 2 seater
170 W X 102 D X 87 H cm

Sofa 3 seater
240 W X 102 D X 87 H cm



SOFRA DINING TABLE
Designer Kaltham Al Kuwari and Aisha Al Mohannadi
270 W X 125 D X 76 H cm



SANAD DINING CHAIR
Designer Kaltham Al Kuwari and Aisha Al Mohannadi
50 W X 60 D X 78 H cm



SANAD DINING ARMCHAIR
Designer Kaltham Al Kuwari and Aisha Al Mohannadi
55 W X 60 D X 78 H cm



TAWLA SIDE TABLE
Designer Shua'a Ali
50 W X 50 D X 50 H cm

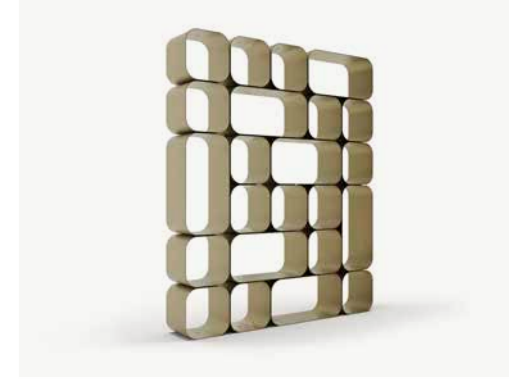

MAKTABA WALL UNIT
Designer Shua'a Ali
Small size
142 W X 30 D X 177 H cm

Large size
177 W X 30 D X 213 H cm

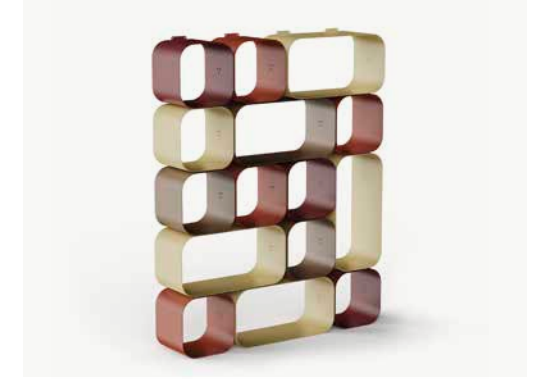

MAKTABA MULTICOLORED WALL UNIT
Designer Shua'a Ali
142 W X 30 D X 177 H cm



MAIZ LARGE COFFEE TABLE
Designer Shua'a Ali
140 W X 80 D X 35 H cm

MAIZ SMALL COFFEE TABLE
Designer Shua'a Ali
80 W X 80 D X 30 H cm



DERJ CONSOLE DESK
Designer Shua'a Ali
130 W X 40 D X 86 H cm

DERJ POUF
Designer Shua'a Ali
80 W X 42 D X 43 H cm



LAITE FLOOR LAMP
Designer Shua'a Ali X Studio Ellaquadro
45 W X 45 D X 180 H cm



LAITE CEILING LAMP
Designer Shua'a Ali X Studio Ellaquadro
33 W X 33 D X 110 H cm

INDEX



ZAL CARPET
Designer Shua'a Ali X KAHHAL 1871
Small size 250 x 220 cm Medium size 300 X 260 cm Large size 360 X 315 cm

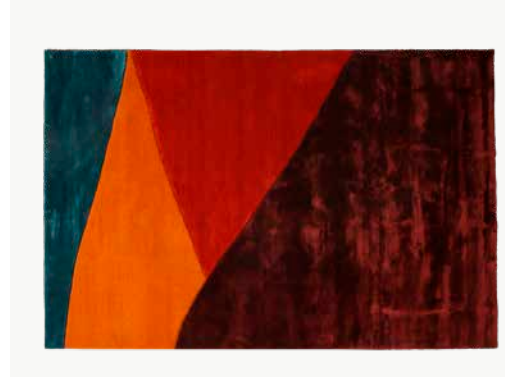

DUNES CARPET
Designer Shua'a Ali X KAHHAL 1871
360 X 315 cm

FINISHING

METAL

Finishing: Matte (powder coating) / Glossy (powder coating + glossy liquid paint)



Gold
Metallic Satin MW136E
Interpon 310, Akzonobel

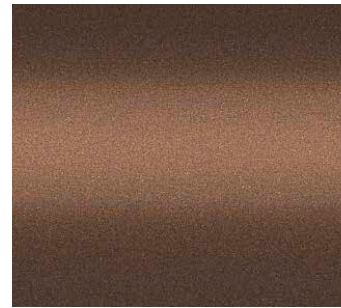

Patah 2525
Metallic Matt YW267I
Interpon D2525, Akzonobel

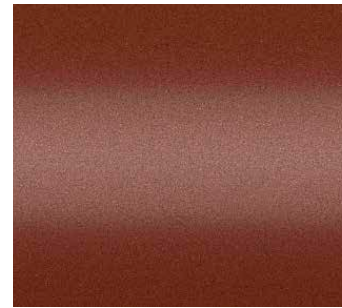

Arches
Metallic Matt YW265F
Interpon D2525 - Akzonobel

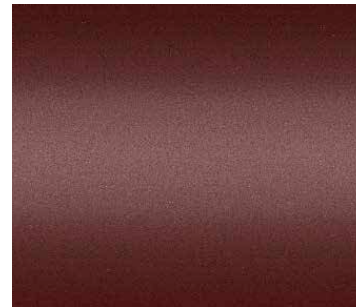

Pamplona
Metallic Matt Y220NI
Interpon D2525, Akzonobel



Luxor
Metallic Matt Y220TI
Interpon D2525, Akzonobel

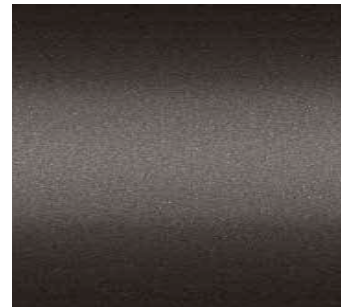

Manganese 2525
Metallic Matt YW280F
Interpon D2525, Akzonobel

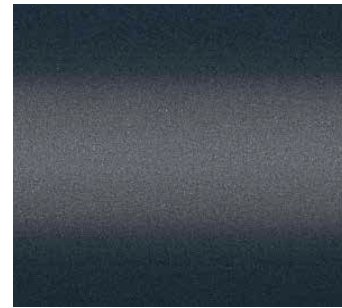

Canon 2525
Metallic Matt YW279F
Interpon D2525, Akzonobel

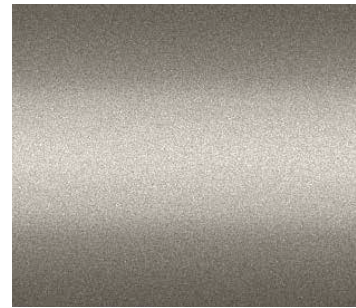

INOX ARL744
Metallic Satin E3510I
Interpon 700 MR, Akzonobel

WOOD / SHELLS



Oak 13 003 (striped)
Tabu



Bolivar TB-P 1232 (light grain)
Tabu



Rosewood Santos (flamed)
Zanuso Legno



2021.05 Natural Shades (flamed) - Bonomi e Pattini / Busnelli



2020.05 New Line (flamed)
Bonomi e Pattini / Busnelli

LEATHERETTE / SHELLS



DAYTONA (leather texture)
TPA Alternative Tessili

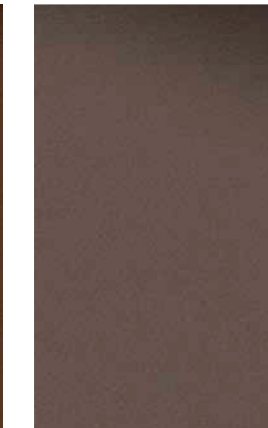

LEATHERETTE / SHELLS & UPHOLSTERY

SATEN (smooth texture)
TPA Alternative Tessili

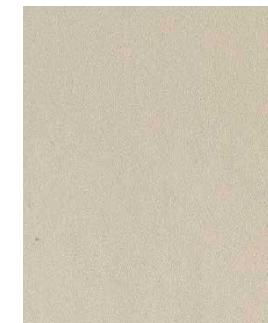

A 1066



N 1234



M 2554

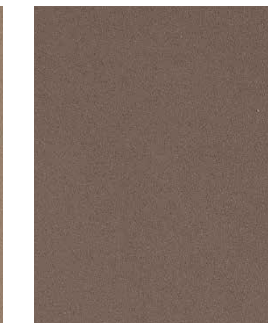

M 1889



N 1236



V 1449

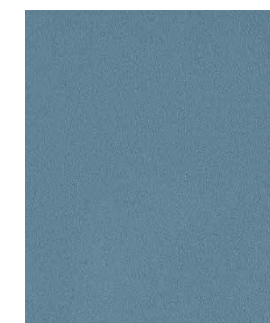

B 1708



B 1714

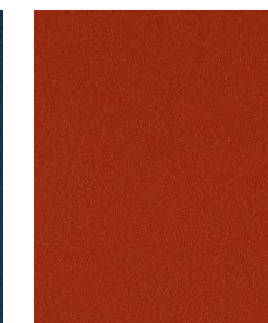

M 2561

FINISHING

GLASS / TABLE TOP



Extra-Clear
Frosted Glass



Bronze
Frosted Glass



Smoked
Frosted Glass

CONCRETE / COFFEE TABLE BOX



Cloudy morn



Dawn



Twilight



Evenfall



Eve

FINISHING

CONCRETE AND WOOD / SIDE TABLE BASE



Cloudy morn



Dawn



Twilight



Evenfall



Eve



Oak 13 003 (striped)
Tabu



Bolivar TB-P 1232 (light grain)
Tabu



Rosewood Santos (flamed)
Zanuso Legno



2021.05 Natural Shades
(flamed) - Bonomi e Pattini /
Busnelli



2020.05 New Line (flamed)
Bonomi e Pattini / Busnelli

DOHA

FROMM. AT M7
M7, FOURTH FLOOR, MSHEIREB
DOHA - QATAR

MILAN

FROMM. AT VIA SAVONA
VIA SAVONA, 35 - 20144
MILAN - ITALY

RETAIL

STUDIO D DECOR
THE GATE MALL, OMAR AL MUKHTAR ST
DOHA - QATAR

PRINTEMPS DOHA
OASIS MALL, AL KHALEEEJ ST
DOHA - QATAR

MUSEUM OF ISLAMIC ART
GIFT SHOP
OFF AL CORNICHE ST, DOHA - QATAR

ROSSANA ORLANDI GALLERY
VIA MATTEO BANDELLO, 14 - 20123
MILAN - ITALY

NATIONAL MUSEUM OF QATAR
GIFT SHOP
MUSEUM PARK ST, DOHA - QATAR

BEYMEN (COMING SOON)
DEPARTMENT STORE
TURKEY

ONLINE

ARTEMEST
WWW.ARTEMEST.COM

EMAIL – SALES@FROM-M.COM
WEBSITE – WWW.FROM-M.COM
INSTAGRAM – @FROMM.LAB / @FROMM.DESIGN

FROMM.

from-m.com